

SERENE®
USER'S MANUAL
Lamp Flasher



Model
CA-LX

Operating Guide

Thank you for purchasing this product, please read before use (Keep this manual for future reference)

Model CA-LX is an optional accessory for **CentralAlert™** Visual Alert System, Model CA-360, designed for indoor use only. When the **CentralAlert™** system is activated, it will send a signal to the CA-LX, which will, in turn activate the connected lamp to begin flashing to alert you that your attention is required.

Installation And Testing:

1. Connect the CA-LX to the **CentralAlert™** Visual Alert System (Model CA-360) as shown using the provided 2.5 mm plug cable. CA-360 output jack marked "External Lamp Cont." should be connected to CA-LX 2.5 mm jack (on the side).
2. Plug the lamp into the CA-LX in the plug port on the bottom of the

English

CA-LX. Turn On the lamp switch.
(Note: Always use a bulb less than 100 watts in rating).

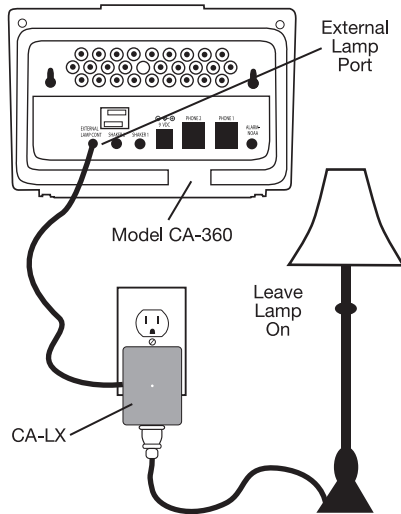

English

3. Plug the CA-LX into a powered, 120 VAC electrical outlet inside your home. Please Note: The CA-LX is designed to be used indoors only. Do not use the CA-LX in an outdoor environment.
4. The CA-LX is now ready to be activated. Test your connection by pressing the **RESET/SNOOZE** button to turn on the flasher on the CA-360. This should also turn on the lamp. If the lamp is not **ON**, toggle the lamp switch until it is **ON**. (Note: Always leave the lamp switch **ON**, otherwise the lamp will not flash).
5. Your connection is now complete and is ready. When CA-360 receives an alert signal, both the CA-360

English

flasher and the connected lamp will flash in synchronism. (Note: The lamp switch to the CA-LX must remain turned on in order for the lamp to flash).

Specifications:

- Input: 120 VAC 60Hz
- Incandescent: 300 watts max.

Caution:

RISK OF ELECTRICAL SHOCK: FOR INDOOR USE ONLY CAUTION: NOT FOR USE WITH DIMMER.



Serene Innovations, Inc.
14731 Carmenita Road, Norwalk, CA. 90650
Toll Free: 866-376 9271, Fax: 562-483-2087
Website: www.sereneinnovations.com
Email: Customercare@Sereneinnovations.com

English